

PRINCIPAL APPLICATIONS

Designed for continuous operation in, chillers, coolers, vending and general water applications

PIPES, FITTINGS AND MOUNTING PLATES

- SPC pumps are fitted to python systems to provide the optimum cooling rate for soft drinks, beers and wines
- Braided hose or brewery tubing complete with fittings available to order
- Alternative mounting plates in stainless steel available to order

WETTED MATERIALS

- PP or stainless steel mounting plate
- Glass filled ABS Column & Pump Body with PP Impellers
- Stainless steel shaft
- Nylon Agitator

FEATURES

- Up to 15.8 litres/minute, Up to 12.1 metres head
- Low maintenance and long life
- Available with plugs and leads to suit application
- Agitator propeller fitted as standard
- Top mounted with keyhole mounting plate
- IPX4 motor housing
- Two stage pump head

OPTIONS

110V or 50/60Hz versions

DIMENSIONS

Drawings not to scale
Dimensions in millimetres

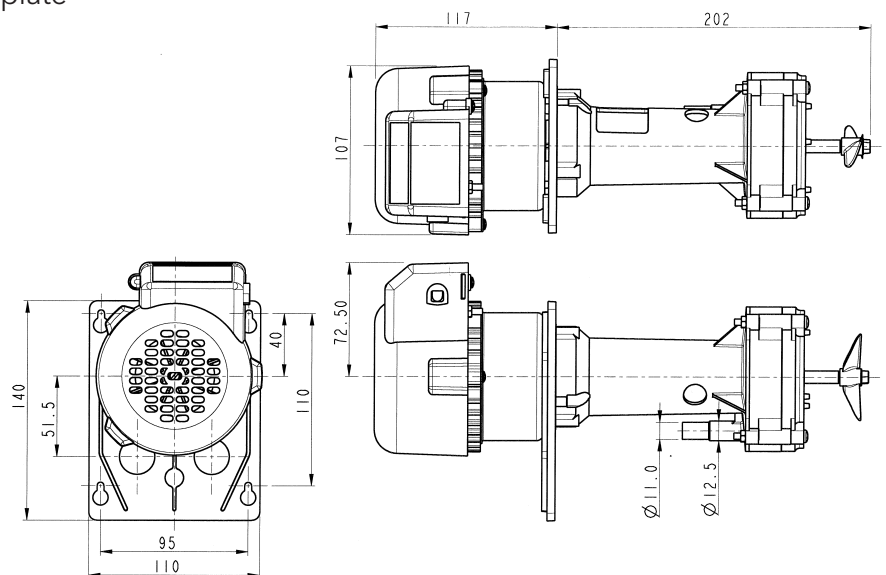

SPECIFICATION

Model	Overall height (mm)	Overall length (mm)	Weight (kg)	Run-out flow rate (l/min)	Closed valve head (m)	Output port (mm)	Temp range (degC)	*Max specific gravity	Motor output (watts)
SPC42	117	319	2.5	50Hz 14.2	12.1	Plain 11/12.5 combined	-20 to +85	1.0	60
				60Hz 15.6	15.4				

*Assuming maximum viscosity of 30cp.

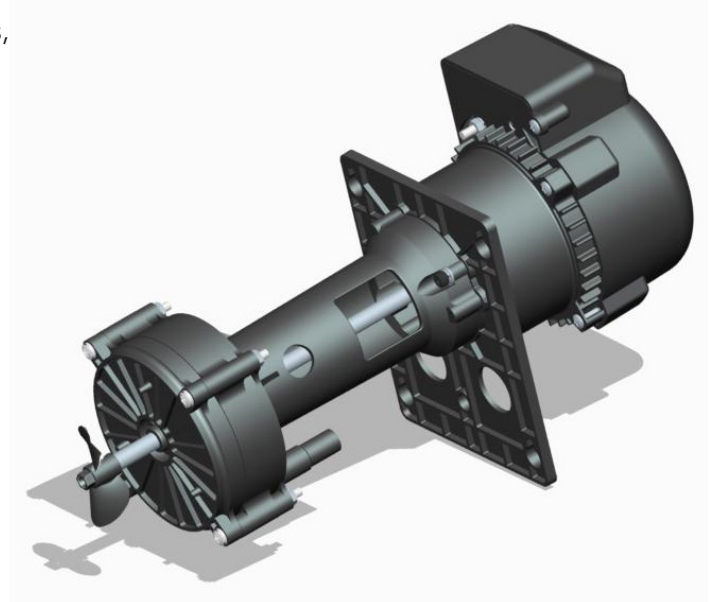

PERFORMANCE

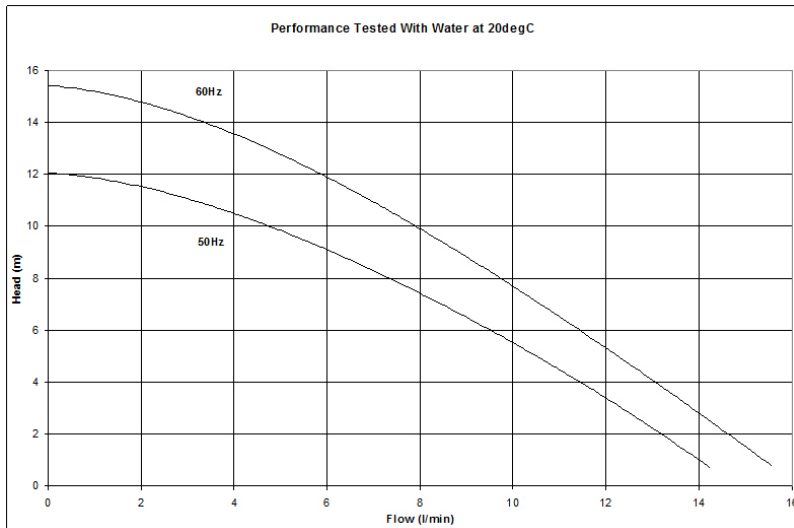

NOTE: These magnetically coupled pumps are designed for use with clean fluids.

Solids will cause jamming. Abrasives will reduce pump life and invalidate the warranty.

The company reserves the right to change specifications.

xylem
Let's Solve Water

www.xyleminc.com

**UK
Xylem**
Bingley Road, Hoddesdon
Hertfordshire EN11 0BU
Tel: +44 (0) 1992 450145
Fax: +44 (0) 1992 467132

**USA
Xylem**
100 Cummings Center Drive
Suite 535-N, Beverly, MA 01915
Tel: +1 978 281-0440
Fax: +1 978 283-2619

**ITALY
Xylem**
Via Tommaseo, 6
20059 Vimercate, Milano
Tel: +39 039 685 2323
Fax: +39 039 666 307

**GERMANY
Xylem**
Oststrasse 28
22844 Norderstedt
Tel: +49-40-53 53 73-0
Fax: +49-40-53 53 73-11

**JAPAN
Xylem**
3-21-10, Shin-Yokohama
Kohoku-Ku, Yokohama, 222-0033
Tel: +81-045-475-8906
Fax: +81-045-477-1162

Warranty: All products of the company are sold, and all services of the company are offered subject to the company's warranty and terms of sale, copies of which will be furnished upon request. Details correct at time of printing. We reserve the right to change specifications without prior notice.